



ISO 9001:2008 / ISO 14001 : 2004
EUROPE CE CERTIFICATION



Technical Data

Condensate Auto Drain Trap

Electric Actuator Ball Valve Type

Model : DM-150B

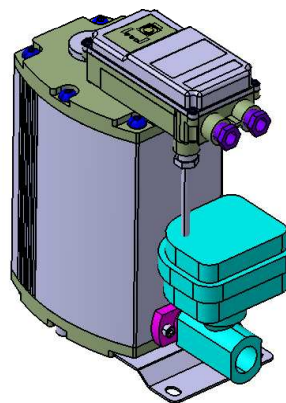

Condensate Auto Drain Trap

DRAIN MASTER B

TECHNICAL DATA

Model	DM - 150B		
Order Ref.	DM 150 BA		
Working Pressure (min/max)	0 ~16 bar		
Temperature (min/max)	+1 °C ~ +80 °C		
Safety Class	IP 65		
Condensate Feed	G3/4"(NPT 3/4") x 3 point		
Venting Line	G3/4"(NPT 3/4")		
Condensate Discharge	G1/2"(NPT 1/2")		
Weight (empty)	3.9 kg		
Scope of Application	Oil-Free Condensate or Oil-Contaminated Condensate		
Material	Housing	Aluminium, Hardcoated	
	O-ring	NBR	
	Valve	Body : SCS13A . Ball : SUS 304	
	PCB Board Casing	ABS	

	Climatic zone	Peak compressor performance m ³ /min	Peak dryer performance m ³ /min	Peak filter performance m ³ /min
DM-150B	Green	170	340	1700
	Blue	150	300	1500
	Red	105	210	1050

***Green** –Dry and cool climate(such as in Northern Europe, Canada, Northern states of the USA, Central Asia)

***Blue** –temperate climate(such as in Central and Southern Europe, Central America)

***Red** –humid, tropical climate(such as in the coastal regions of South-East Asia, Oceania, Amazon and Congo regions)

Discharge Capacity of DRAIN MASTER B (DM-150B)

Working pressure	1 bar	2 bar	3 bar	4 bar	5 bar	6 bar	7 bar
Peak load (l/h)	180	210	240	275	310	352	400

Voltage	Standard	100~240Vac(Free Voltage) / 50~60Hz	
	Order Voltages	24Vac.48Vac /24Vdc.48Vdc	
Power Input	10.0 VA	Fuse protection(normal lag)	0.5 A
Cable cross section	Ø 6.0 ~ 8.0 mm; 3 x 0.75mm		

Thermostatically controlled heating (Option)

Designation	Heater Unit	
Order Ref.	A DM00-1	A DM00-2
Power	220Vac/50~60Hz/125W	110Vac/50~60Hz/125W
Operating Pressure(max)	25 bar	
with heating unit and proper insulation; down to -25 °C		

DIMENSION

DRAIN MASTER B (DM-150B)

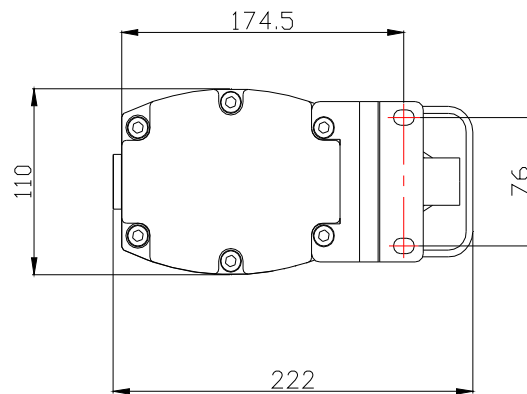
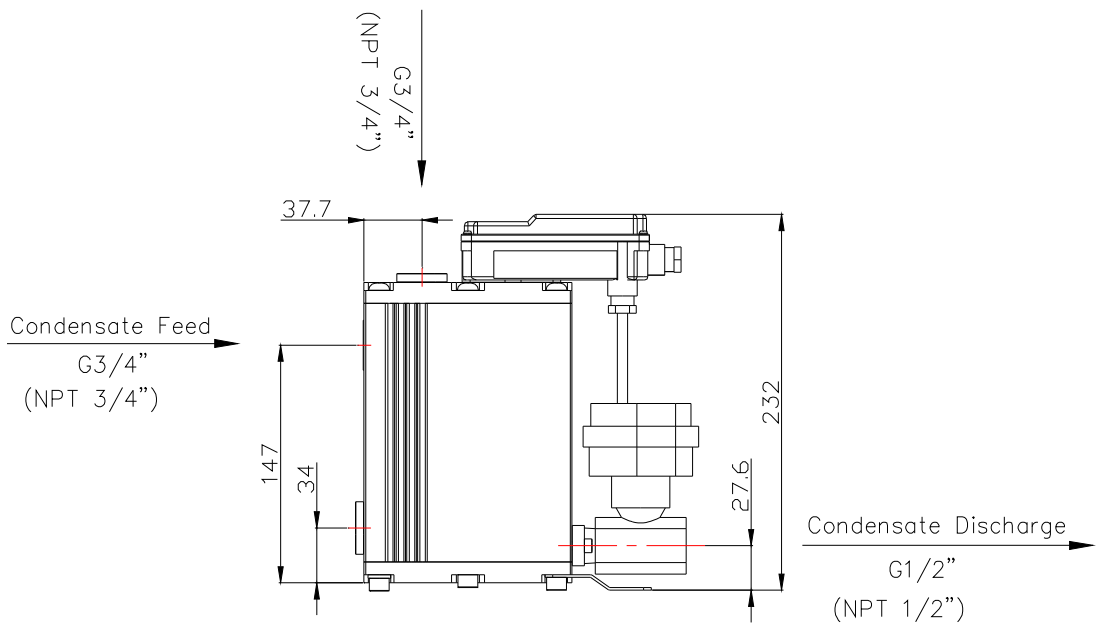
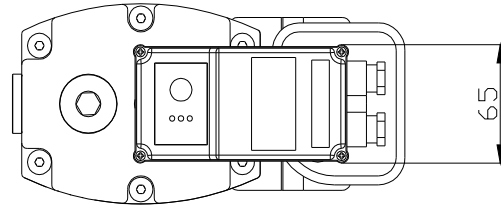
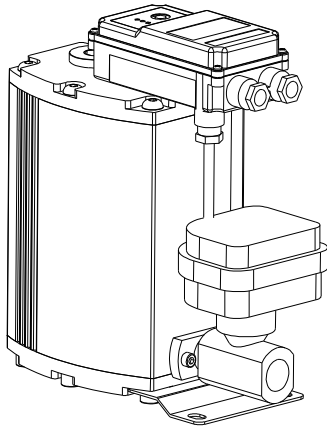

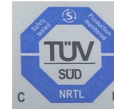

Enclosure type:
4X "Watertight"
EnE System, co., Ltd

ISO 9001:2008 / ISO 14001 : 2004
EUROPE CE CERTIFICATION



Technical Data

Condensate Auto Drain Trap

Electric Actuator Ball Valve Type

Model : DM-500B

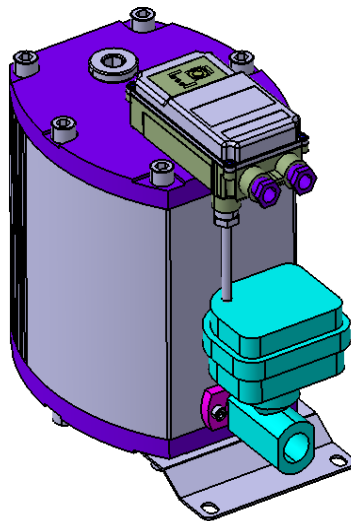

Condensate Auto Drain Trap

DRAIN MASTER B

TECHNICAL DATA

Model	DM - 500B		
Order Ref.	DM 500 BA		
Working Pressure (min/max)	0 ~16 bar		
Temperature (min/max)	+1°C ~ +80°C		
Safety Class	IP 65		
Condensate Feed	G3/4"(NPT 3/4") x 3 point		
Venting Line	G3/4"(NPT 3/4")		
Condensate Discharge	G3/4"(NPT 3/4")		
Weight (empty)	6.0 kg		
Scope of Application	Oil-Free Condensate or Oil-Contaminated Condensate		
Material	Housing	Aluminium, Hardcoated	
	O-ring	NBR	
	Valve	Body : SCS13A . Ball : SUS 304	
	PCB Board Casing	ABS	

	Climatic zone	Peak compressor performance m ³ /min	Peak dryer performance m ³ /min	Peak filter performance m ³ /min
DM-500B	Green	570	1140	.
	Blue	500	1000	.
	Red	350	700	.

*Green -Dry and cool climate(such as in Northern Europe, Canada, Northern states of the USA, Central Asia)

*Blue -temperate climate(such as in Central and Southern Europe, Central America)

*Red -humid, tropical climate(such as in the coastal regions of South-East Asia, Oceania, Amazon and Congo regions)

Discharge Capacity of DRAIN MASTER B (DM-500B)

Working pressure	1 bar	2 bar	3 bar	4 bar	5 bar	6 bar	7 bar
Peak load (l/h)	400	460	520	590	670	750	850

Voltage	Standard	100~240Vac(Free Voltage) / 50~60Hz	
	Order Voltages	24Vac.48Vac /24Vdc.48Vdc	
Power Input	10.0 VA	Fuse protection(normal lag)	0.5 A
Cable cross section	Ø 6.0 ~ 8.0 mm; 3 x 0.75mm		

Thermostatically controlled heating (Option)

Designation	Heater Unit	
Order Ref.	A DM00-1	A DM00-2
Power	220Vac/50~60Hz/125W	110Vac/50~60Hz/125W
Operating Pressure(max)	25 bar	
with heating unit and proper insulation; down to -25°C		

DIMENSION

DRAIN MASTER B (DM-500B)

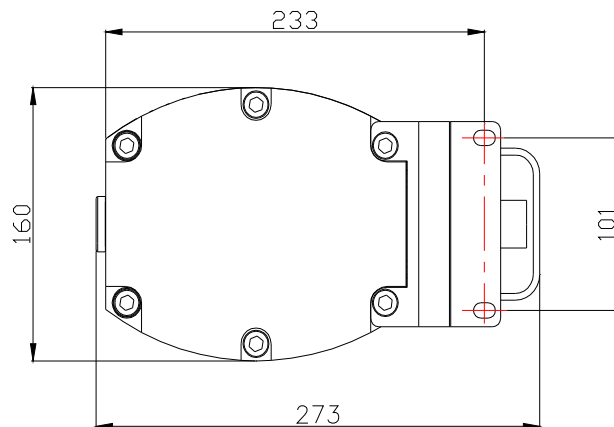
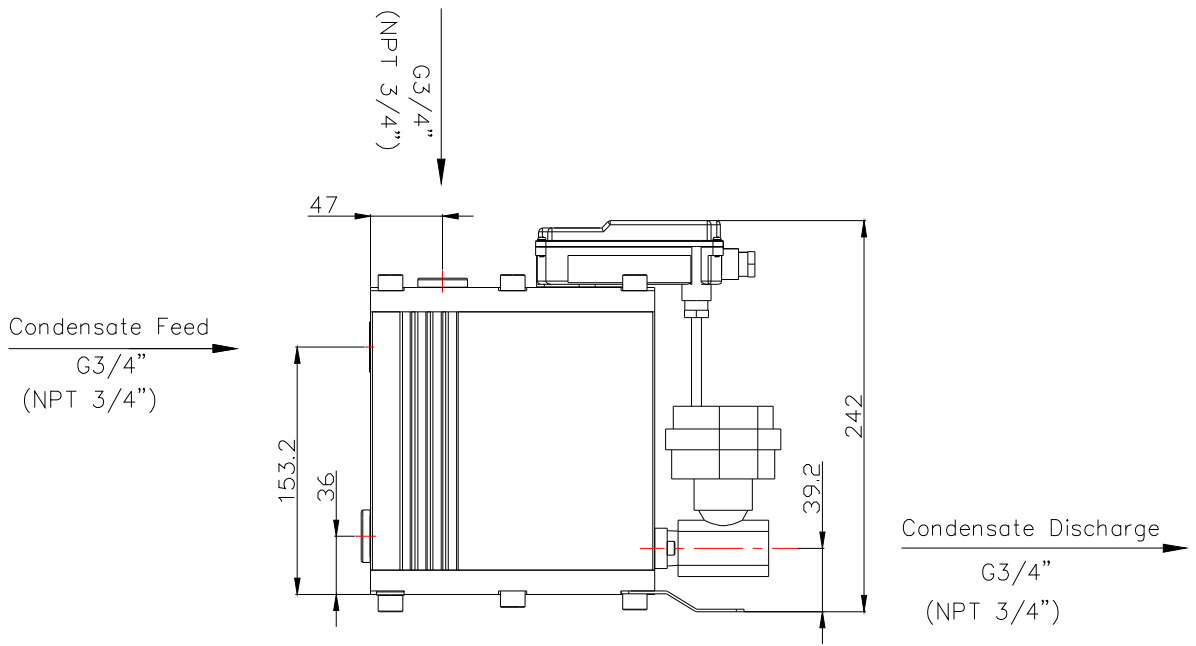
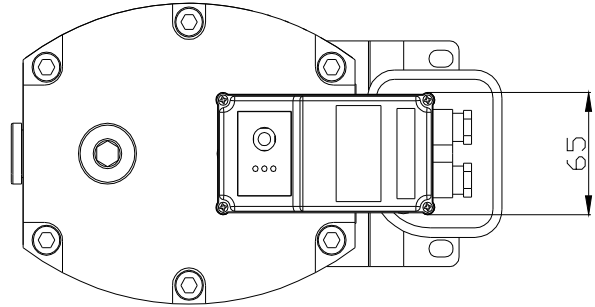
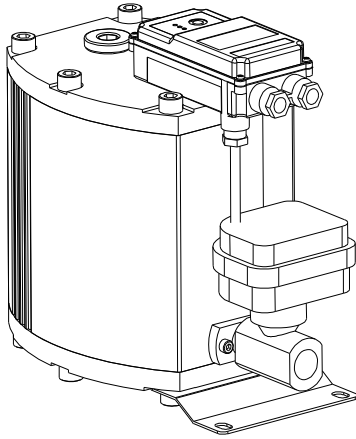

Subject to technical changes without prior notice, errors not excluded.



ISO 9001:2008 / ISO 14001 : 2004
EUROPE CE CERTIFICATION



Technical Data

Condensate Auto Drain Trap

Electric Actuator Ball Valve Type

Model : DM-1500B

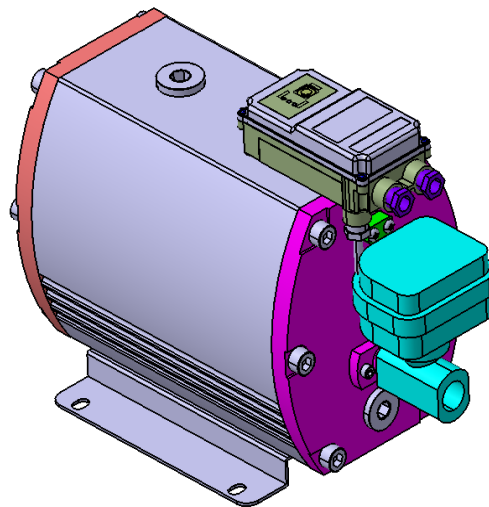

Condensate Auto Drain Trap

DRAIN MASTER B

TECHNICAL DATA

Model	DM - 1500B		
Order Ref.	DM 1500 BA		
Working Pressure (min/max)	0 ~16 bar		
Temperature (min/max)	+1 °C ~ +80 °C		
Safety Class	IP 65		
Condensate Feed	G3/4"(NPT 3/4") x 2 point, G1"(NPT 1") x 1 point		
Venting Line	G3/4"(NPT 3/4")		
Condensate Discharge	G3/4"(NPT 3/4")		
Weight (empty)	7.5 kg		
Scope of Application	Oil-Free Condensate or Oil-Contaminated Condensate		
Material	Housing	Aluminium, Hardcoated	
	O-ring	NBR	
	Valve	Body : SCS13A . Ball : SUS 304	
	PCB Board Casing	ABS	

	Climatic zone	Peak compressor performance m ³ /min	Peak dryer performance m ³ /min	Peak filter performance m ³ /min
DM-1500B	Green	1750	3500	.
	Blue	1500	3000	.
	Red	1050	2100	.

***Green** -Dry and cool climate(such as in Northern Europe, Canada, Northern states of the USA, Central Asia)

***Blue** -temperate climate(such as in Central and Southern Europe, Central America)

***Red** -humid, tropical climate(such as in the coastal regions of South-East Asia, Oceania, Amazon and Congo regions)

Discharge Capacity of DRAIN MASTER B (DM-1500B)

Working pressure	1 bar	2 bar	3 bar	4 bar	5 bar	6 bar	7 bar
Peak load (l/h)	950	1,150	1,320	1,400	1,460	1,580	1,700

Voltage	Standard	100~240Vac(Free Voltage) / 50~60Hz					
	Order Voltages	24Vac.48Vac /24Vdc.48Vdc					
Power Input	10 VA	Fuse protection(normal lag)				0.5 A	
Cable cross section	Ø 6.0 ~ 8.0 mm; 3 x 0.75mm						

Thermostatically controlled heating (Option)

Designation	Heater Unit	
Order Ref.	A DM00-1	A DM00-2
Power	220Vac/50~60Hz/125W	110Vac/50~60Hz/125W
Operating Pressure(max)	25 bar	
with heating unit and proper insulation; down to -25 °C		

DIMENSION

DRAIN MASTER B (DM-1500B)

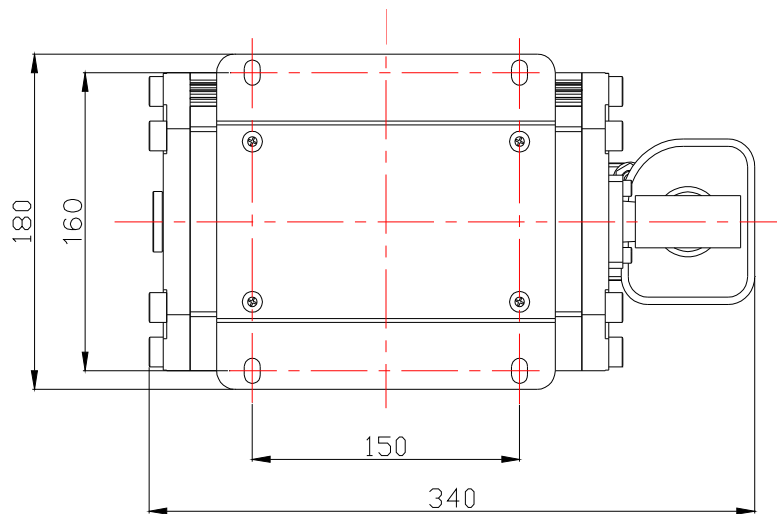
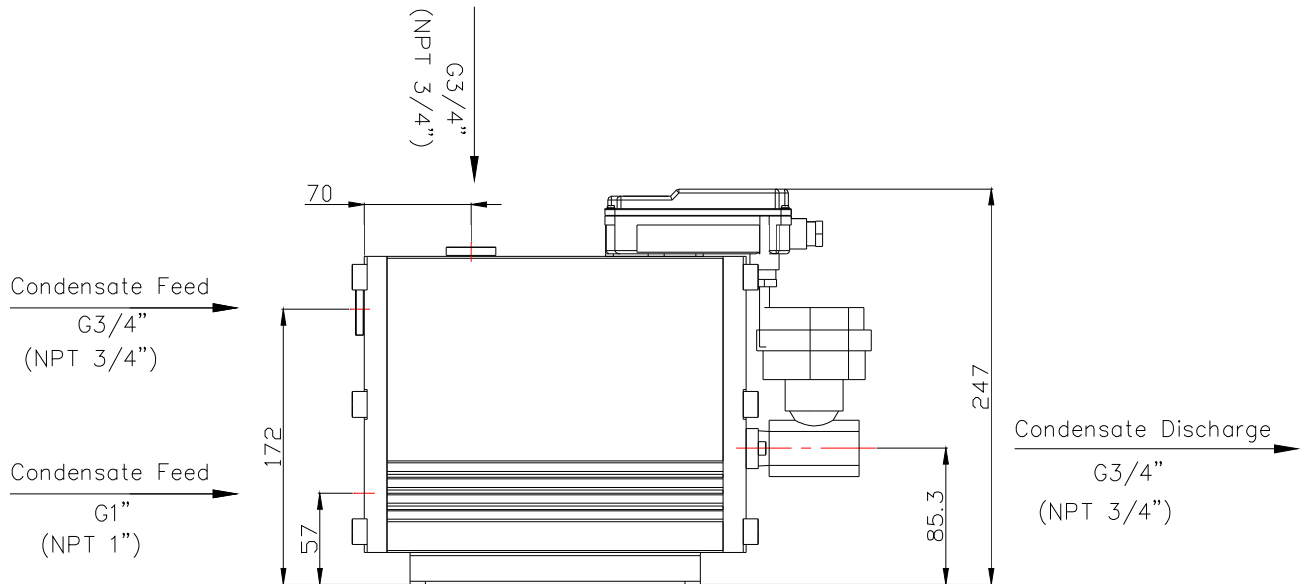
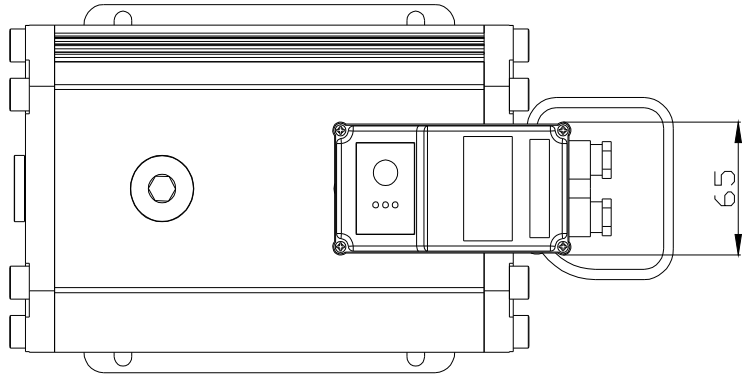
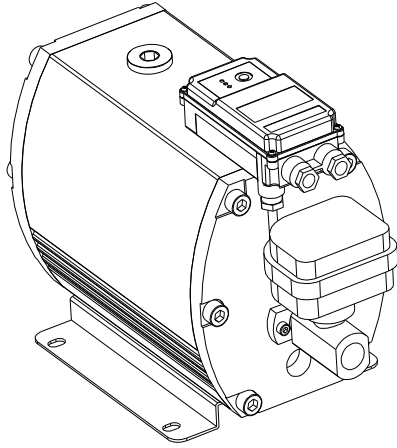

Subject to technical changes without prior notice, errors not excluded.