



ISO 9001:2008 ISO 14001:2008

Technical Data

Oil-Water Separator

Standard

Model : YUSOO-15

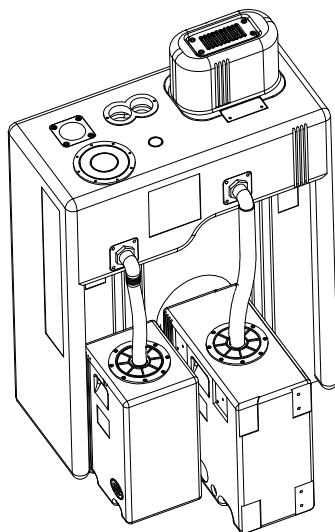

TECHNICAL DATA

Model	YUSOO-15
Order Ref.	YUSOO 015 000
Container + Filter Volume	180.7 liter
Container Volume	154 liter
Filter Volume	1 x 26.7 liter
Condensate Feed (hose mm inside)	3/4" . (di 32mm Hose)
Water Discharge (hose mm inside)	1" . (di 32mm Hose)
Oil Discharge (hose mm inside)	1" . (di 32mm Hose)
Weight (empty)	Approx. 29 Kg
Temperature (min/max . °C)	+5 ~ 60
Scope of Application	Oil-Contaminated Condensate

Condensate & Installed Compressor Capacity

		Scerw Compressor				Piston Compressor	
		Turbine oil	VCL-oil	VDL-oil	Synthetic -oil	Turbine oil	Synthetic -oil
Condensate Capacity (ℓ/h)		18.2	15	18.2	13.2 ~15.0	14.5	11.0 ~12.8
Compressor Capacity (m ³ /min)	Green	17.5	14.5	17.5	13.0~14.5	14.0	10.5~12.3
	Blue	15.0	12.5	15.0	11.0~12.5	12.0	9.0~10.3
	Red	12.5	10	12.5	9.0~10.2	9.8	7.4~8.6

***Green** -Dry and cool climate(such as in Northern Europe, Canada, Northern states of the USA, Central Asia)
 ***Blue** -temperate climate(such as in Central and Southern Europe, Central Americal)
 ***Red** -humid, tropical climate(such as in the coastal regions of South-East Asia, Oceania, Amazon and Congo regions)

▶VCL-Oil : Mineral + Synthetic Oil ▶VDL-Oil : Mineral Oil

Materials

Pressure relief chamber	HDPE(Poly Ethylene)
Container	HDPE(Poly Ethylene)
Adsorption filter	Activated Carbon
Pre filter	PP(Poly Propylene)
Filter Container	HDPE(Poly Ethylene)

- ▶ Must attach automatic thermostat(option : Heater) in freezing area.
- ▶ Else above models are custom-built.
- ▶ Above specification can be changed without advance notice for improvement of performance(2013.01)

DIMENSION

YUSOO-BREAKER (YUSOO-15)

